

GaussDB

Billing

Issue 01
Date 2024-09-29



Copyright © Huawei Cloud Computing Technologies Co., Ltd. 2024. All rights reserved.

No part of this document may be reproduced or transmitted in any form or by any means without prior written consent of Huawei Cloud Computing Technologies Co., Ltd.

Trademarks and Permissions



HUAWEI and other Huawei trademarks are the property of Huawei Technologies Co., Ltd.

All other trademarks and trade names mentioned in this document are the property of their respective holders.

Notice

The purchased products, services and features are stipulated by the contract made between Huawei Cloud and the customer. All or part of the products, services and features described in this document may not be within the purchase scope or the usage scope. Unless otherwise specified in the contract, all statements, information, and recommendations in this document are provided "AS IS" without warranties, guarantees or representations of any kind, either express or implied.

The information in this document is subject to change without notice. Every effort has been made in the preparation of this document to ensure accuracy of the contents, but all statements, information, and recommendations in this document do not constitute a warranty of any kind, express or implied.

Huawei Cloud Computing Technologies Co., Ltd.

Address: Huawei Cloud Data Center Jiaoxinggong Road
Qianzhong Avenue
Gui'an New District
Gui Zhou 550029
People's Republic of China

Website: <https://www.huaweicloud.com/intl/en-us/>

Contents

1 Billing Overview	1
2 Billed Items	3
3 Billing Modes	7
3.1 Overview.....	7
3.2 Yearly/Monthly Billing.....	8
3.3 Pay-per-Use Billing.....	12
4 Billing Examples	16
5 Billing Mode Changes	19
5.1 Overview.....	19
5.2 Pay-per-Use to Yearly/Monthly.....	20
5.3 Yearly/Monthly to Pay-per-Use.....	23
6 Subscription Renewal	26
6.1 Overview.....	26
6.2 Manually Renewing a GaussDB Instance.....	27
6.3 Auto-renewing a GaussDB Instance.....	30
7 Bills	33
8 Arrears	38
9 Billing Termination	40
10 Cost Management	43

1 Billing Overview

In this document, you will learn about how GaussDB instances are billed, how you can renew subscriptions and manage costs, and what happens if your account goes into arrears.

- **Billing Modes**

GaussDB provides two billing modes, yearly/monthly billing and pay-per-use billing, to meet requirements in different scenarios.

- Yearly/Monthly: You pay upfront for the amount of time you expect to use the DB instance for. You will need to make sure you have a top-up account with a sufficient balance or have a valid payment method configured first.
- Pay-per-use: You can start using the DB instance first and then pay as you go.

For more details, see [Overview](#).

You can also change the billing mode later if it no longer meets your needs. For details, see [Overview](#).

- **Billed Items**

You will be billed for the DB instance, storage space, backup space, and EIP bandwidth. For details about the billing factors and formulas for each billed item, see [Billed Items](#).

For more information about the billing samples and the billing for each item, see [Billing Examples](#).

- **Renewing Subscriptions**

After a yearly/monthly DB instance expires, it cannot run properly. If you want to continue using a DB instance after it expires, you need to renew the DB instance subscription within the specified period. Otherwise, compute and storage resources will be automatically released, and data may be lost.

You can renew your subscriptions manually or automatically. For more details, see [Overview](#).

- **Viewing Bills**

You can choose **Billing & Costs > Bills** to check the DB instance transactions and bills. For details, see [Bills](#).

- **Arrears**

If there is not a sufficient account balance to pay for your bill and there is no other payment method configured, your account will go into arrears. If you want to continue using your cloud services, you will need to top up your account in a timely manner. For details, see [Arrears](#).

- **Stopping Billing**

If you no longer need to use your cloud service, you can unsubscribe from or delete it to stop the billing. For details, see [Billing Termination](#).

2 Billed Items

Description

You will be billed for the DB instance, storage space, backup space, and EIP bandwidth. For details, see [Table 2-1](#).

 **NOTE**

The billed items marked with asterisks (*) are mandatory.

Table 2-1 GaussDB billed items

Billed Item	Description	Billing Mode	Formula
*DB instance	Billed by instance specifications, including vCPUs and memory. Computing and storage capabilities vary by the number of vCPUs and memory size.	Yearly/Monthly and pay-per-use	<p>Unit price of a single node x Required duration x Number of billed nodes</p> <p>The unit price of a single node varies depending on the instance specifications. For details, see section "Specification Price" on GaussDB Pricing Details.</p> <p>NOTE</p> <p>Number of billed nodes = Number of coordinator nodes (CNs) + Number of data nodes (DNs)</p> <ul style="list-style-type: none"> • Independent deployment: If you retain the default configurations for an instance, including three shards (each containing three replicas, namely, three DN) and three CNs, there will be a total of nine DN in the instance, and the number of billed nodes is 12 (3 CNs + 9 DN). • HA (1 primary + 2 standby): There are three DN in an instance, and the number of billed nodes is 3.

Billed Item	Description	Billing Mode	Formula
*Storage space	Billed by storage type and capacity based on unified standards.	Yearly/Monthly and pay-per-use	<p>Unit price of the storage space x Required duration x Storage capacity (GB)</p> <p>For details about the unit price of the storage space, see section "Storage Space Price" on GaussDB Pricing Details.</p>
Backup space	Billed based on unified standards.	Pay-per-use	<p>Unit price of the backup space x Billed duration x (Backup capacity – Storage capacity) (GB)</p> <p>For details about the unit price of the backup space, see section "Backup Storage Price" on GaussDB Pricing Details.</p> <p>NOTE</p> <ul style="list-style-type: none"> The billed duration refers to the length of time the billed backup space was used for.

Billed Item	Description	Billing Mode	Formula
EIP bandwidth	<p>An EIP is required if a DB instance needs to access the Internet.</p> <p>Billed by bandwidth, traffic, and the EIP reservation price.</p> <ul style="list-style-type: none"> EIP for a yearly/monthly DB instance: billed by bandwidth. EIP for a pay-per-use DB instance: billed by bandwidth, traffic, or shared bandwidth. You are also charged for IP reservation if you do not bind the EIP to any instance. 	<p>Yearly/Monthly and pay-per-use</p> <p>You can purchase a bandwidth add-on package or a shared traffic package.</p>	<p>Tiered pricing based on fixed bandwidth</p> <ul style="list-style-type: none"> 0 Mbit/s to 5 Mbit/s (included): billed at a fixed unit price per Mbit/s Greater than 5 Mbit/s: billed at a different price per Mbit/s <p>For details about the unit price, see section "Bandwidth Price" on ECS Pricing Details, or see EIP Pricing Details.</p>

3 Billing Modes

3.1 Overview

GaussDB provides two billing modes, yearly/monthly billing and pay-per-use billing, to meet requirements in different scenarios.

- **Yearly/Monthly** is a prepaid billing mode. You pay in advance for a subscription term, and in exchange, you get a discounted rate. The longer the subscription term, the bigger the discount. Yearly/Monthly billing is a good option for long-term, stable services.
- **Pay-per-use** is a postpaid billing mode. You pay as you go and just pay for what you use. The DB instance usage is calculated by the second but billed every hour. This allows you to adjust resource usage easily. You neither need to prepare for resources in advance, nor end up with excessive or insufficient preset resources. Pay-per-use billing is a good option for scenarios where there are sudden traffic bursts, such as e-commerce promotions.

Table 3-1 Billing modes

Billing Mode	Yearly/Monthly	Pay-per-Use
Payment	Prepaid Billed by the subscription term you purchase.	Postpaid Billed by service duration.
Billing Method	Billed by the subscription term you purchase.	Calculated by the second but billed every hour.
Billed Items	Instance specifications (vCPUs and memory), storage space, backup space, and EIPs	Instance specifications (vCPUs and memory), storage space, backup space, and EIPs

Billing Mode	Yearly/Monthly	Pay-per-Use
Changing the Billing Mode	Yearly/Monthly can be changed to pay-per-use. The change takes effect only after the yearly/monthly subscription expires. Yearly/Monthly to Pay-per-Use	Pay-per-use can be changed to yearly/monthly. Pay-per-Use to Yearly/Monthly
Changing the Specifications	Supported	Supported
Application Scenario	Recommended for resources expected to be in use long-term. A cost-effective option for scenarios where the resource usage duration is predictable.	Recommended when the resource demands are likely to fluctuate and you want more flexibility.

3.2 Yearly/Monthly Billing

If you expect to use resources for a longer period, you can save money by selecting yearly/monthly billing. You can pre-purchase GaussDB instances at discounted prices. This section describes the billing rules for yearly/monthly GaussDB instances.

Application Scenarios

If you want to ensure resource stability over a certain period of time, yearly/monthly billing is a good choice for the following types of workloads:

- Long-term workloads with stable resource requirements, such as official websites, online malls, and blogs.
- Long-term projects, such as scientific research projects and large-scale events.
- Workloads with predictable traffic bursts, for example, e-commerce promotions or festivals.
- Workloads with high data security requirements

Billed Items

You are billed for the following items on a yearly/monthly basis.

Table 3-2 Items billed on a yearly/monthly basis

Billed Item	Description
DB instance	CNs and DNs are billed on a yearly/monthly basis. Management nodes, including CMSs and GTMs, are not billed.

Billed Item	Description
Storage space	If the actual storage usage exceeds your purchased storage, you will be billed for additional storage on a pay-per-use basis.
(Optional) Backup space	GaussDB provides free backup storage equal to the amount of your purchased storage space. After the free backup space is used up, charges are applied based on the backup space pricing details. Pricing is listed on a per-hour basis, but bills are calculated based on the actual usage duration.
EIP bandwidth	GaussDB instances can be accessed through a public network, and traffic fees are generated accordingly. You are not billed for traffic generated through a private network.

Suppose you want to purchase a one-month distributed DB instance with 8 vCPUs and 64 GB of memory, and the instance contains 1 shard, 3 replicas, 1 CN, and 160 GB of storage. At the bottom of the **Buy DB Instance** page shown in [Figure 3-1](#), you can view the total price (excluding the backup space price) of the current instance.

Figure 3-1 Example price

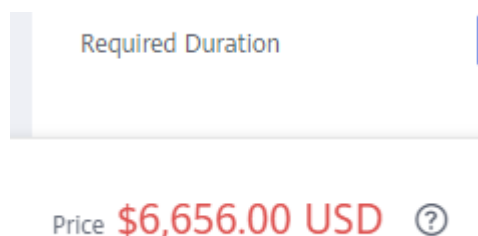

NOTE

The backup space price is not included. For details about the backup price, see [Price Calculator](#).

Backup Storage Price

Billing Method	Hourly	Currency
Linear billing	0.000044	Price per GB

Billed Usage Period

A yearly/monthly DB instance is billed for the purchased duration. The billing starts when you activated or renewed the subscription, and ends at 23:59:59 of the expiry date.

For example, if you purchased a one-month DB instance on March 08, 2023, 15:50:04, the billed usage period is from March 08, 2023, 15:50:04 to April 08, 2023, 23:59:59.

Billing Examples

Suppose you purchased a one-month distributed GaussDB instance (1 shard, 3 replicas, 1 CN, General-enhanced II, 8 vCPUs, 64 GB of memory, and 160 GB of storage) on March 08, 2023, 15:50:04, and renewed the subscription for one more month before the initial subscription expired. The following usage periods will be billed:

- March 08, 2023, 15:50:04 to April 08, 2023, 23:59:59
- April 08, 2023, 23:59:59 to May 08, 2023, 23:59:59
 - From April 08, 2023, 23:59:59 to May 01, 2023, 23:59:59, 60 GB of free backup space was used.
 - From May 01, 2023, 23:59:59 to May 08, 2023, 23:59:59, another 10 GB of backup space was used, which was billed for 168 hours.

Figure 3-2 shows how the total price is calculated.

NOTICE

The prices in the figure are just examples. The actual prices are those displayed on [GaussDB Pricing Details](#).

Figure 3-2 Total price for a yearly/monthly GaussDB instance

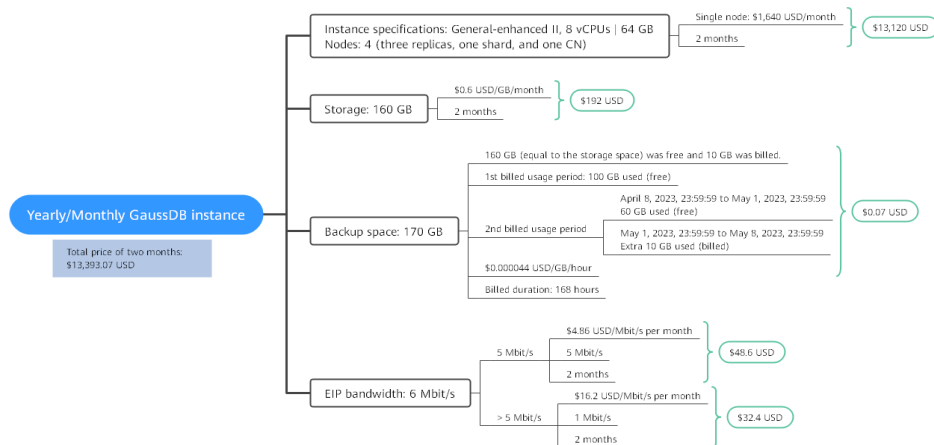

Price Change After Specification Change

If the specifications of a yearly/monthly GaussDB instance no longer meet your needs, you can change the specifications on the console. The system will recalculate the price and either bill or refund you the difference.

- If you upgrade your instance specifications, you need to pay the difference in price.

- If you downgrade your instance specifications, Huawei Cloud will refund you the difference.

You are not advised to downgrade your DB instance to lower specifications because instance performance may be affected. Suppose you purchased a one-month primary/standby GaussDB instance (8 vCPUs | 64 GB) on April 08, 2023 and upgraded the instance specifications to 16 vCPUs | 128 GB on April 18, 2023. The price of the original specifications was \$1,640 USD/month, and that for the new specifications was \$3,280 USD/month. The price difference will be calculated as follows:

Specification upgrade fee = New specification price × Remaining period - Old specification price × Remaining period

The remaining period is the remaining days of each calendar month divided by the maximum number of days in each calendar month. In this example, Remaining period = 12 (Remaining days in April)/30 (Maximum number of days in April) + 8 (Remaining days in May)/31 (Maximum number of days in May) = 0.6581. Cost of upgrade = \$3,280 USD × 0.6581 – \$1,640 USD × 0.6581 = \$1,079.28 USD

For more details, see [Pricing of a Changed Specification](#).

Impact of Expiration

Figure 3-3 shows the statuses a yearly/monthly GaussDB instance can go through throughout its lifecycle. After a DB instance is purchased, it enters the valid period and runs normally during this period. If the DB instance is not renewed after it expires, before being deleted, it first enters a grace period and then a retention period.

Figure 3-3 Lifecycle of a yearly/monthly GaussDB instance

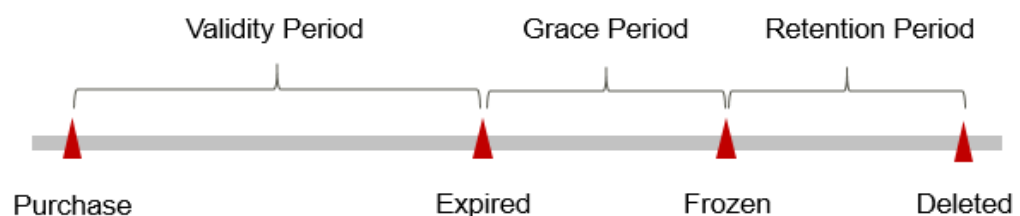

Expiration Reminder

The system will send you a reminder (by email, SMS, or in-app message) 7 days before a yearly/monthly DB instance expires to remind you to renew the subscription.

Impact of Expiration

If your yearly/monthly DB instance is not renewed after it expires, it changes to the **Expired** state and enters a grace period. During the grace period, you can access the DB instance but cannot:

- Change instance specifications
- Change the billing mode from yearly/monthly to pay-per-use

- Unsubscribe from the DB instance

If the yearly/monthly DB instance is not renewed after the grace period ends, its status turns to **Frozen** and it enters a retention period. You cannot perform any operations on the DB instance while it is in the retention period.

If the yearly/monthly DB instance is not renewed by the time the retention period ends, it will be released and data cannot be restored.

 **NOTE**

- The grace period and retention period are both 15 days.
- For details about renewals, see [Overview](#).

3.3 Pay-per-Use Billing

Pay-per-use billing means you pay nothing up front and are not tied into any contract or commitment. This section describes the billing rules for pay-per-use GaussDB instances.

Application Scenarios

Pay-per-use billing is good for short-term, bursty, or unpredictable workloads that cannot tolerate any interruptions, such as applications for e-commerce flash sales, temporary testing, and scientific computing.

Billed Items

You are billed for the following items on a pay-per-use basis.

Table 3-3 Items billed on a pay-per-use basis

Billed Item	Description
DB instance	CNs and DNs are billed on a pay-per-use basis. Management nodes, including CMSs and GTMs, are not billed.
Database storage (pay as you use)	Instance storage space, which is billed hourly on a pay-per-use basis.
Backup storage (pay as you use)	GaussDB provides free backup storage equal to the amount of your purchased storage space. After the free backup space is used up, charges are applied based on the backup space pricing details. Pricing is listed on a per-hour basis, but bills are calculated based on the actual usage duration.
(Optional) EIP bandwidth	GaussDB instances can be accessed through a public network, and traffic fees are generated accordingly. You are not billed for traffic generated through a private network.

Suppose you want to purchase a pay-per-use distributed DB instance with general-enhanced II specifications, 8 vCPUs, and 64 GB of memory, and the instance contains 1 shard, 3 replicas, 1 CN, and 160 GB of storage. At the bottom of the **Buy DB Instance** page, you can view pricing details (excluding the backup space prices).

Figure 3-4 Example prices

Price **\$13.5744 USD**/hour 

NOTE

The backup space price is not included. For details about the backup price, see the **Product Pricing Details** page of the [price calculator](#).

Backup Storage Price

Billing Method	Hourly	Currency
Linear billing	0.000044	Price per GB

Billed Usage Period

Pay-per-use DB instance usage is calculated by the second and billed every hour. The billing starts when the DB instance is launched and ends when the instance is deleted.

NOTE

It takes a certain time to create a GaussDB instance. The billing starts from the time when the instance was successfully created.

For example, if you purchased a pay-per-use DB instance at 8:45:30 and deleted it at 8:55:30, you are billed for the 600 seconds from 8:45:30 to 8:55:30.

Billing Examples

Suppose you purchased a pay-per-use distributed DB instance on April 18, 2023, 9:59:30 with general-enhanced II specifications, 8 vCPUs, and 64 GB of memory, and the instance contains 1 shard, 3 replicas, 1 CN, and 160 GB of storage. Then you deleted it on April 18, 2023, 10:45:46. The following usage periods will be billed:

- April 18, 2023, 9:00:00 to April 18, 2023, 10:00:00
Usage of 30 seconds from 9:59:30 to 10:00:00
- April 18, 2023, 10:00:00 to April 18, 2023, 11:00:00
Usage of 2,746 seconds from 10:00:00 to 10:45:46
 - From April 18, 2023, 10:00:00 to April 18, 2023, 10:45:00, free backup space was used.

- From April 18, 2023, 10:45:00 to April 18, 2023, 10:45:46, an extra 10 GB of backup space was used, which was billed for 46 seconds.

Figure 3-5 shows how the total price is calculated.

NOTICE

The prices in the figure are just examples. The actual prices are those displayed on [GaussDB Pricing Details](#).

For pay-per-use billing, decimal numerals on the price calculator are rounded off and are accurate to two decimal places. If the fee is less than \$0.01 USD (after rounding off), \$0.01 USD will be displayed.

Figure 3-5 Total price for a pay-per-use DB instance

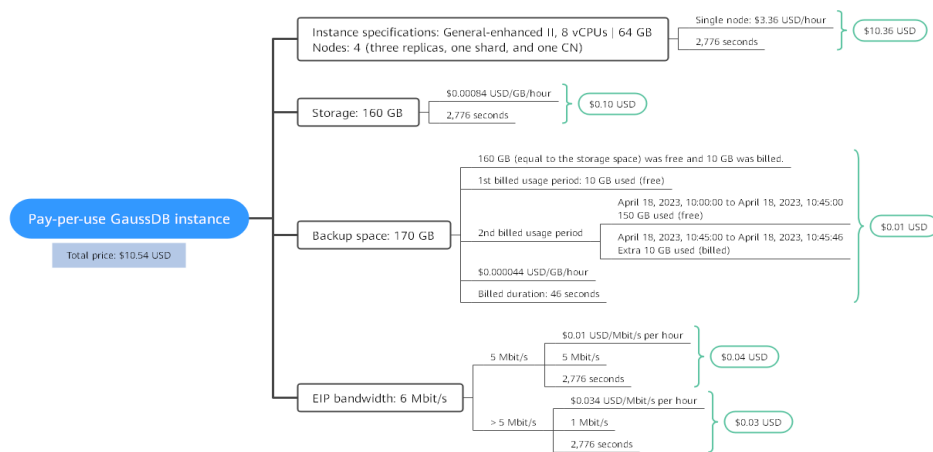

Price Change After Specification Change

If you change the specifications of a pay-per-use instance, the original order will become invalid and a new order will be placed. You will be billed based on the new specifications.

If you change instance specifications within a given hour, multiple records will be generated. Different records record the billing for different specifications.

For example, if you purchased a pay-per-use DB instance (8 vCPUs | 64 GB) at 9:00:00 and changed the instance specifications to 16 vCPUs | 128 GB at 9:30:00, the following items will be billed:

- DB instance (8 vCPUs | 64 GB) usage from 9:00:00 to 9:30:00
- DB instance (16 vCPUs | 128 GB) usage from 9:30:00 to 10:00:00

Impact of Arrears

Figure 3-6 shows the statuses a pay-per-use DB instance can have throughout its lifecycle. After a DB instance is purchased, it enters the valid period and runs normally during this period. If your account goes into arrears, the DB instance enters a grace period and then a retention period.

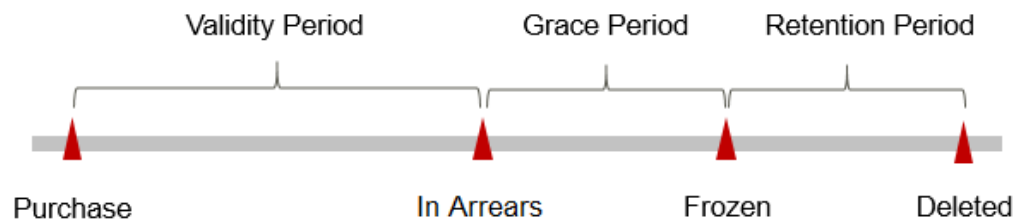
Figure 3-6 Lifecycle of a pay-per-use DB instance

Arrears Reminder

The system will bill you for pay-per-use resources after each billing cycle ends. If your account goes into arrears, we will notify you by email, SMS, or in-app message.

Impact of Arrears

If your account is insufficient to pay your amount due, your account goes into arrears, and the pay-per-use instance enters the grace period. You are still responsible for expenditures generated during the grace period. You can view the charges on the **Billing & Costs > Overview** page and pay any past due balance as needed.

If you do not bring your account balance current before the grace period expires, the DB instance turns to **Frozen** and enters a retention period.

If you do not bring your account balance current before the retention period ends, the DB instance will be released and the data cannot be restored.

NOTE

- The grace period and retention period are both 15 days.
- For details about top-up, see [Topping Up an Account](#).

4 Billing Examples

Billing Scenario

A user purchased a pay-per-use distributed GaussDB instance at 8:30:00 on March 20, 2023. The instance configuration is as follows:

- Instance specifications: General-enhanced II, 8 vCPUs | 64 GB, one shard, three replicas, and one CN
- Storage space: 160 GB
- EIP bandwidth: 6 Mbit/s

After a period of time, the user found that the current DB instance specifications no longer met service requirements and updated the specifications to 16 vCPUs | 128 GB at 10:00:00 on March 20, 2023. Since the user wanted to use the DB instance long term, the user then changed the instance to yearly/monthly billing with a one-month duration at 10:30:00 on the same day. So how much will the user be billed for this DB instance in March and April?

Billing Analysis

The total price of this DB instance involves both pay-per-use and yearly/monthly usage:

- Pay-per-use usage: March 20, 2023, 8:30:00 to March 20, 2023, 10:30:00
 - March 20, 2023, 8:30:00 to March 20, 2023, 10:00:00
 - Instance specifications: General-enhanced II, 8 vCPUs | 64 GB, one shard, three replicas, and one CN
 - Used storage space: 40 GB
 - Used backup space: 40 GB
 - EIP bandwidth: 6 Mbit/s
 - March 20, 2023, 10:00:00 to March 20, 2023, 10:30:00
 - Instance specifications: General-enhanced II, 16 vCPUs | 128 GB, one shard, three replicas, and one CN

- Used storage space: 20 GB
- Used backup space: 30 GB
- EIP bandwidth: 6 Mbit/s
- Yearly/Monthly usage: March 20, 2023, 10:30:00 to April 20, 2023, 23:59:59
 - Instance specifications: General-enhanced II, 16 vCPUs | 128 GB, one shard, three replicas, and one CN
 - Used storage space: 80 GB
 - Used backup space: 100 GB (billed on a pay-per-use basis from April 19, 2023, 23:59:59 to April 20, 2023, 23:59:59)
 - EIP bandwidth: 6 Mbit/s
 - Billed duration: one month

Pay-per-use

From March 20, 2023, 8:30:00 to March 20, 2023, 10:00:00, an instance with specifications 8 vCPUs | 64 GB was used for 1.5 hours, so the price would be calculated as follows.

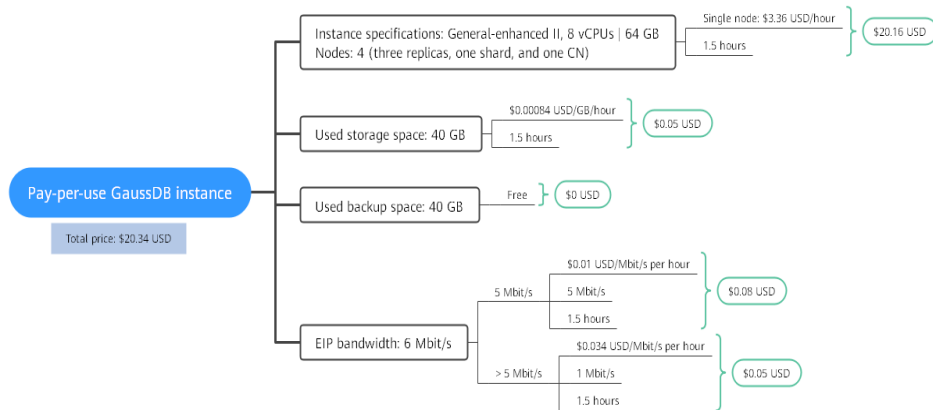

From March 20, 2023, 10:00:00 to March 20, 2023, 10:30:00, a DB instance with specifications 16 vCPUs | 128 GB was used for 0.5 hour, so the price would be calculated as follows.

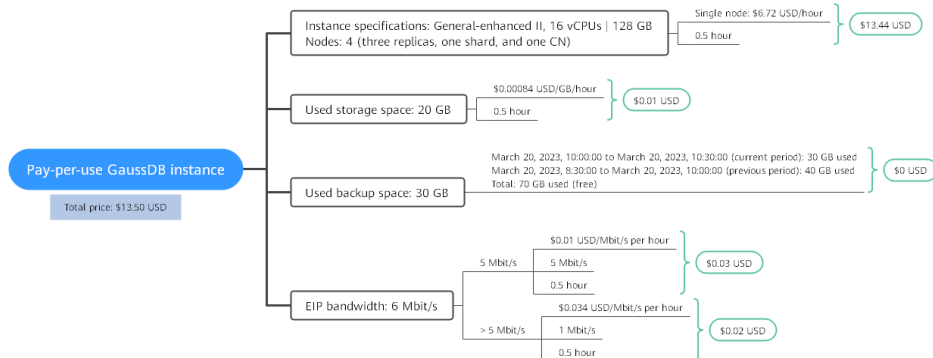

Yearly/Monthly

From March 20, 2023, 10:30:00 to April 20, 2023, 23:59:59, a DB instance purchased using yearly/monthly billing was used for one month, so the price would be calculated as follows.

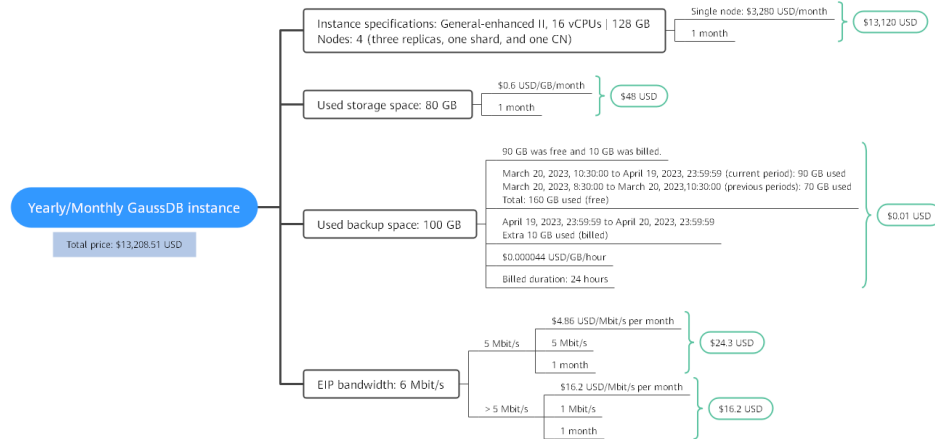

From March to April, the total price of this GaussDB instance is \$13,242.35 USD (20.34 + 13.50 + 13,208.51).

5 Billing Mode Changes

5.1 Overview

You can change the billing mode if it no longer meets your needs. [Table 5-1](#) lists the changeable GaussDB billed items.

Table 5-1 Changeable GaussDB billed items

Billed Item	Change Description	Reference
DB instance specifications (vCPUs and memory)	<p>Changing the billing mode of a DB instance includes the changes to compute resources (vCPUs and memory), the storage space, and backup space.</p> <ul style="list-style-type: none">• Change from pay-per-use to yearly/monthly to enjoy lower prices.• Change from yearly/monthly to pay-per-use to use the DB instance more flexibly. <p>NOTE Such a change takes effect only after the yearly/monthly subscription ends.</p>	<ul style="list-style-type: none">• Pay-per-Use to Yearly/Monthly• Yearly/Monthly to Pay-per-Use

Billed Item	Change Description	Reference
EIP	<ul style="list-style-type: none"> A yearly/monthly EIP can be changed to a pay-per-use EIP billed by bandwidth after the yearly/monthly subscription ends. A pay-per-use EIP billed by bandwidth can be changed to a yearly/monthly EIP. Pay-per-use EIPs billed by bandwidth can be changed to pay-per-use EIPs billed by traffic, and pay-per-use EIPs billed by traffic can be changed to pay-per-use EIPs billed by bandwidth. <p>For details, see Figure 5-1.</p>	<ul style="list-style-type: none"> Pay-per-Use to Yearly/Monthly Yearly/Monthly to Pay-per-Use

Figure 5-1 EIP billing mode change in GaussDB

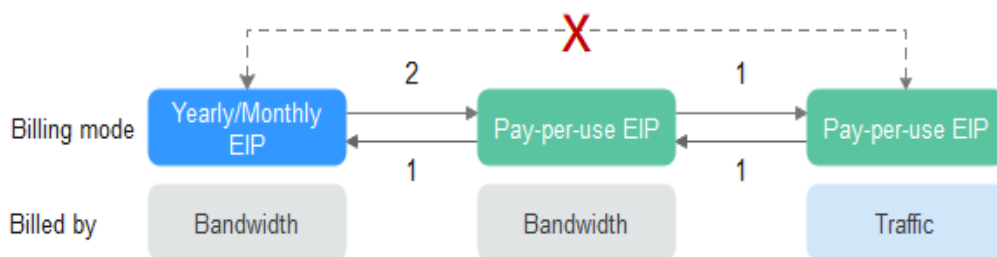

- 1: The change takes effect immediately.
- 2: The change takes effect only after the yearly/monthly subscription period expires.
- x: The billing mode cannot be changed.

5.2 Pay-per-Use to Yearly/Monthly

If you have a pay-per-use DB instance that you expect to use for a long time, you can change it to yearly/monthly billing to reduce costs. Doing so will create an order. After you pay for the order, yearly/monthly billing will be applied immediately.

Suppose you bought a pay-per-use DB instance at 15:29:16 on April 18, 2023 and changed it to yearly/monthly billing at 16:30:30 on the same day. After you paid for the order, yearly/monthly billing was applied immediately. On the **Billing Center > Billing** page, three line items were generated, one for each of the hours the instance was used on a pay-per-use basis, and one for the yearly/monthly subscription:

- Pay-per-use expenditures for 15:29:16 to 16:00:00 on April 18, 2023

- Pay-per-use expenditures for 16:00:00 to 16:30:30 April 18, 2023
- A single, yearly/monthly expenditure generated at 16:30:30 on April 18, 2023

Constraints

Resources such as EIPs that are used by an instance may not support the change with this instance. For details about their billing mode change rules and handling methods, see [Table 5-2](#).

Table 5-2 EIP billing mode change rules

Billed By	Bandwidth Type	Change to Yearly/Monthly Billing with the DB Instance	Handling Measure
Bandwidth	Dedicated	Not supported	Change the EIP to yearly/monthly billing on the EIP console. For details, see Changing the EIP Billing Mode .
Traffic	Dedicated	Not supported	An EIP that is billed by traffic on a pay-per-use basis cannot be directly changed to be billed on a yearly/monthly basis. To change this: <ol style="list-style-type: none">1. Change the EIP to be billed by bandwidth on a pay-per-use basis.2. Change the EIP to be billed on a yearly/monthly basis. For details, see Changing the EIP Billing Mode .

Precautions

- The billing mode of the instance must be pay-per-use.
- Pay-per-use instances in any of the following statuses cannot be changed to yearly/monthly instances: frozen, creation failed, changing instance specifications, and scaling up.
- Changing the billing mode from pay-per-use to yearly/monthly does not affect services.

Changing the Billing Mode of a Single DB Instance

Step 1 [Log in to the management console](#).

Step 2 Click  in the upper left corner and select a region and a project.

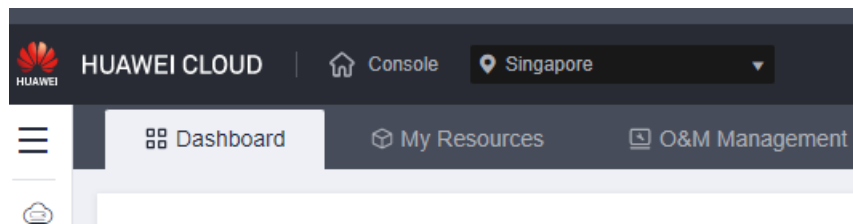

- Step 3** Click  in the upper left corner of the page and choose **Databases > GaussDB**. The GaussDB console is displayed.
- Step 4** On the **Instances** page, locate the target pay-per-use instance and choose **More > Change to Yearly/Monthly** in the **Operation** column.
- Step 5** Select how many months you want to renew the subscription for. The minimum duration is one month.
- If you do not need to modify your settings, click **Pay** to go to the payment page.
 - If you are not sure about the settings, you can click **Submit & Pay Later**. The system will reserve your order. You can choose **Billing Center > My Orders** in the upper right corner and pay or cancel the order.
- Step 6** Select a payment method and click **Confirm**.
- Step 7** View the result on the **Instances** page.

In the upper right corner of the instance list, click  to refresh the list. After the change completes, the instance status will change to **Available** and the billing mode will change to **Yearly/Monthly**.

----End

Changing the Billing Mode of DB Instances in Batches

NOTE

Only pay-per-use instances can be changed to yearly/monthly instances.
The status of pay-per-use DB instances must be **Available** or **Abnormal**.

- Step 1** [Log in to the management console](#).
- Step 2** Click  in the upper left corner and select a region and a project.

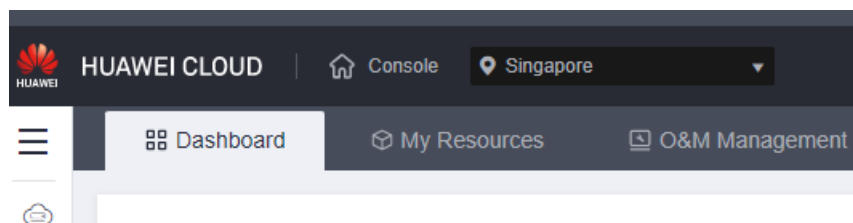

- Step 3** Click  in the upper left corner of the page and choose **Databases > GaussDB**. The GaussDB console is displayed.

- Step 4** On the **Instances** page, select all the target pay-per-use DB instances and click **Change to Yearly/Monthly** above the instance list.
- Step 5** Select how many months you want to renew the subscription for. The minimum duration is one month.
- If you do not need to modify your settings, click **Pay** to go to the payment page.
 - If you are not sure about the settings, you can click **Submit & Pay Later**. The system will reserve your order. You can choose **Billing Center > My Orders** in the upper right corner and pay or cancel the order.
- Step 6** Select a payment method and click **Confirm**.
- Step 7** View the results on the **Instances** page.

In the upper right corner of the instance list, click  to refresh the list. After the change completes, the instance status will change to **Available** and the billing mode will change to **Yearly/Monthly**.

----End

5.3 Yearly/Monthly to Pay-per-Use

After creating a yearly/monthly DB instance, you can change it to pay-per-use for more flexibility, and you can recoup part of what you paid for the subscription.

Suppose you bought a yearly/monthly DB instance at 15:29:16 on April 18, 2023 and changed it to pay-per-use billing at 16:30:00 on May 18, 2023. On the **Billing Center > Billing** page, bills information is generated as follows:

- Yearly/Monthly expenditures for 15:29:16 on April 18 to 23:59:59 on May 18, 2023
- Pay-per-use expenditures for 23:59:59 on May 18, 2023 to the end time of pay-per-use billing. A bill was generated every hour.

NOTE

Pay-per-use billing will be applied only after the yearly/monthly billing duration ends. Auto-renewal will not be in effect.

Constraints

Resources such as EIPs that are used by an instance may not support the change with this instance. For details about their billing mode change rules and handling methods, see [Table 5-3](#).

Table 5-3 EIP billing mode change rules

Billed By	Bandwidth Type	Change to Pay-per-Use Billing with the DB Instance	Handling Measure
Bandwidth	Dedicated	Not supported	Directly change it on the console. For details, see Changing the EIP Billing Mode .
Traffic	Dedicated	Not supported	An EIP billed on a yearly/monthly basis cannot be directly changed to be billed by traffic on a pay-per-use basis. To change this: <ol style="list-style-type: none">1. Change the EIP to be billed by bandwidth on a pay-per-use basis.2. Change the EIP to be billed by traffic on a pay-per-use basis. For details, see Changing the EIP Billing Mode .

Precautions

The billing mode can only be changed from yearly/monthly to pay-per-use for DB instances whose order status is **Provisioned**. You can view the order status on the **Billing Center > Renewals** page.

Changing the Billing Mode of a Single DB Instance

Step 1 [Log in to the management console](#).

Step 2 Click  in the upper left corner and select a region and a project.

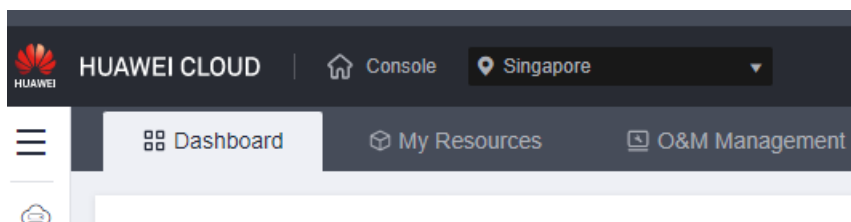

Step 3 Click  in the upper left corner of the page and choose **Databases > GaussDB**. The GaussDB console is displayed.

Step 4 On the **Instances** page, locate the target yearly/monthly DB instance and choose **More > Change to Pay-per-use** in the **Operation** column.

Step 5 On the displayed page, change the billing mode of the instance.

Step 6 View the result on the **Instances** page.

In the upper right corner of the instance list, click  to refresh the list. After the change completes, the instance status will change to **Available** and the billing mode will change to **Pay-per-use**.

----End

Changing the Billing Mode of DB Instances in Batches

NOTE

Only yearly/monthly DB instances can be changed to pay-per-use.

The status of DB instances must be **Available** or **Abnormal**.

The pay-per-use billing mode will be applied only after the yearly/monthly billed duration ends, and auto-renewal will be not in effect.

Step 1 [Log in to the management console](#).

Step 2 Click  in the upper left corner and select a region and a project.

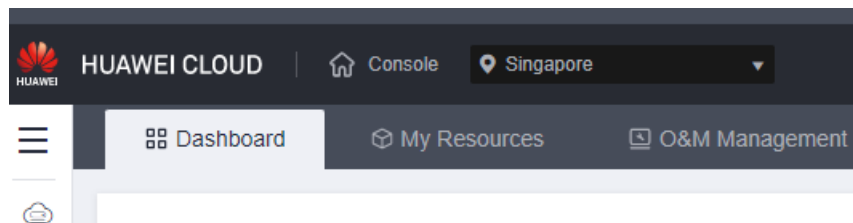

Step 3 Click  in the upper left corner of the page and choose **Databases > GaussDB**. The GaussDB console is displayed.

Step 4 On the **Instances** page, select all the target yearly/monthly DB instances and click **Change to Pay-per-Use** above the instance list.

Step 5 On the displayed page, change the billing mode of the instances.

Step 6 View the results on the **Instances** page.

In the upper right corner of the instance list, click  to refresh the list. After the change completes, the instance status will change to **Available** and the billing mode will change to **Pay-per-use**.

----End

6 Subscription Renewal

6.1 Overview

When to Renew Subscriptions

If a yearly/monthly DB instance is about to expire but you want to continue using it, you need to renew the instance subscription within a specified period, or resources, such as vCPUs and memory, will be automatically released, and data will be lost and cannot be restored.

Only yearly/monthly instance subscriptions can be renewed. If you use pay-per-use instances, just ensure that your account has a valid payment method configured or a top-up account with a sufficient balance.

If you renew a DB instance before it expires, resources will be retained and you can continue using the instance. For details about instance statuses after they have expired and the associated impacts, see [Impact of Expiration](#).

How to Renew Subscriptions

You can renew a yearly/monthly instance manually or automatically.

Table 6-1 Renewing a yearly/monthly instance

Method	Description
Manually Renewing a GaussDB Instance	You can renew a yearly/monthly DB instance anytime on the console before it is automatically deleted.
Auto-renewing a GaussDB Instance	You can enable auto-renewal to automatically renew the DB instance before it expires. This prevents resources from being deleted in case you forget to renew a subscription.

You can select a method to renew a yearly/monthly DB instance based on the phase the instance is currently in.

Figure 6-1 Selecting a renewal method based on the instance's current phase

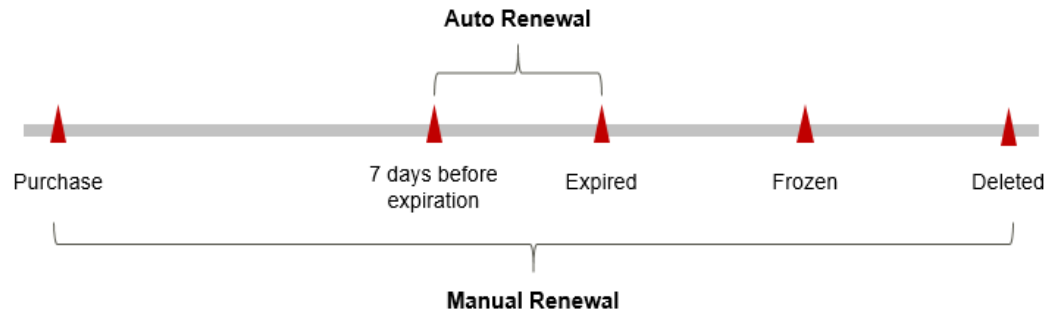

- A DB instance is in the available state after it is provisioned.
- When an instance subscription expires, the instance status will change to **Expired**.
- If an expired GaussDB instance is not renewed, it enters a grace period. If it is not renewed by the time the grace period expires, the instance will be frozen and enter a retention period.
- If you do not renew the subscription before the retention period expires, your resources will be automatically deleted.

NOTE

The grace period and retention period are both 15 days.

You can enable auto-renewal any time before an instance expires. By default, the system will make the first attempt to charge your account for the renewal at 03:00 seven days before the expiry date. If this attempt fails, it will make another attempt at 03:00 every day until the subscription is renewed or expired. You can change the auto-payment date for renewal as required.

6.2 Manually Renewing a GaussDB Instance

You can renew a yearly/monthly GaussDB instance anytime on the console before it is automatically deleted.

Renewing a Subscription on the Console

Step 1 [Log in to the management console](#).

Step 2 Click  in the upper left corner and select a region and a project.

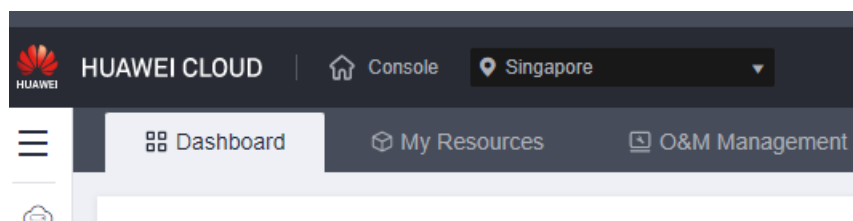

Step 3 Click  in the upper left corner of the page and choose **Databases > GaussDB**. The GaussDB console is displayed.

Step 4 On the **Instances** page, locate the target yearly/monthly DB instance and choose **More > Renew** in the **Operation** column.

Alternatively, click the DB instance name to go to the **Basic Information** page. In the **Billing Information** area, click **Renew** on the right of **Billing Mode**.

Figure 6-2 Renewing a yearly/monthly DB instance

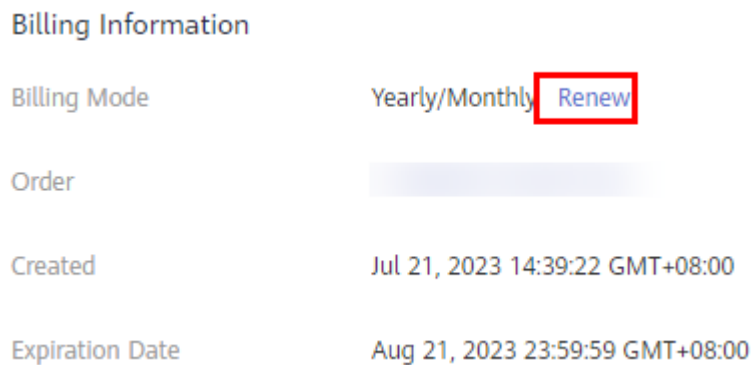

Billing Information	
Billing Mode	Yearly/Monthly Renew
Order	
Created	Jul 21, 2023 14:39:22 GMT+08:00
Expiration Date	Aug 21, 2023 23:59:59 GMT+08:00

Step 5 On the **Renew** page, select a renewal duration and optionally select **Renew on the standard renewal date**. For details, see [Setting the Same Renewal Day for Yearly/Monthly Resources](#). Confirm the price and click **Pay**.

Step 6 Select a payment method and make your payment. Once the order is paid for, the renewal is complete.

----End

Renewing a Subscription in Billing Center

Step 1 [Log in to the management console](#).

Step 2 Hover over **Billing & Costs** in the upper part of the console and choose **Renewal** from the drop-down list.

The **Renewals** page is displayed.

Step 3 Set the search criteria.

On the **Manual Renewals**, **Auto Renewals**, **Pay-per-Use After Expiration**, and **Renewals Canceled** pages, you can view the resources to be renewed.

Figure 6-3 Renewal management

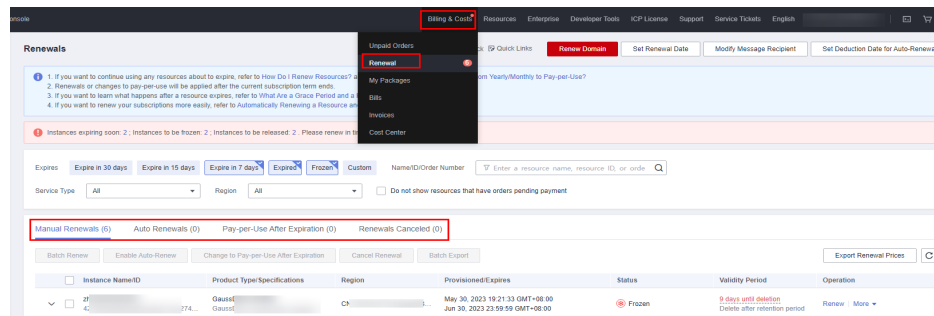

You can move all resources that need to be manually renewed to the **Manual Renewals** page. For details, see [Restoring to Manual Renewal](#).

Step 4 Manually renew resources.

- Individual renewal: Click **Renew** in the **Operation** column for the desired resource.

Figure 6-4 Individual renewal

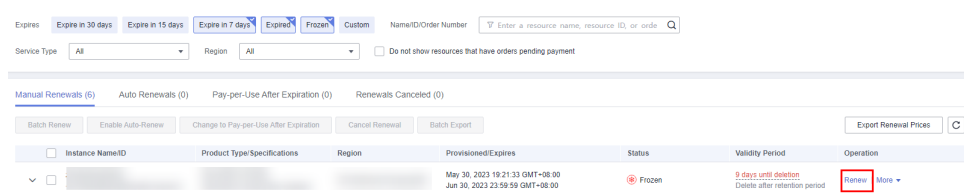

- Batch renewal: Check the boxes for the desired resources, and click **Batch Renew** in the upper left corner.

Figure 6-5 Batch renewal

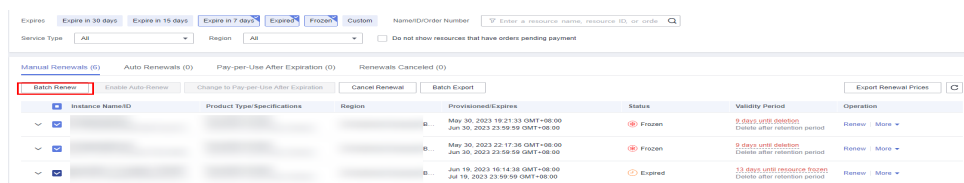

Step 5 Select a renewal duration and optionally select **Renew on the standard renewal date**. For details, see [Setting the Same Renewal Day for Yearly/Monthly Resources](#). Confirm the price and click **Pay**.

Step 6 Select a payment method and make your payment. Once the order is paid for, the renewal is complete.

----End

Setting the Same Renewal Day for Yearly/Monthly Resources

If the DB instances have different expiry dates, you can set the same renewal day, for example, the first day of each month, to make it easier to manage renewals.

In [Figure 6-6](#), a user sets the same renewal day for two resources that will expire at different dates.

Figure 6-6 Setting the same renewal day for resources with different expiry dates

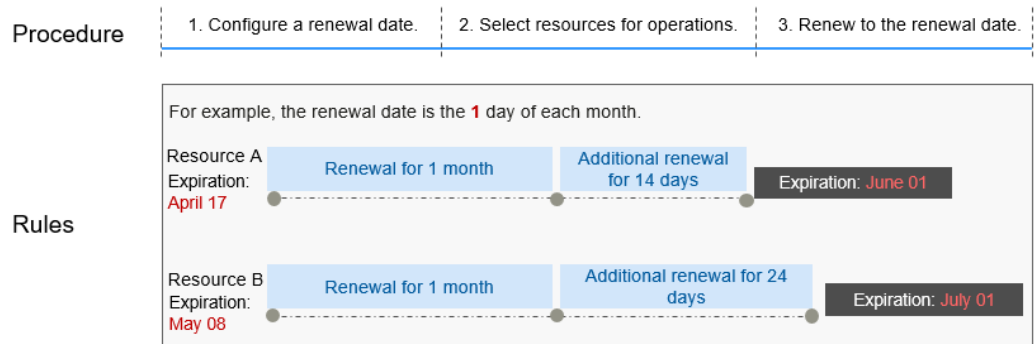

For more details, see [Setting a Renewal Date](#).

6.3 Auto-renewing a GaussDB Instance

Auto-renewal can prevent DB instances from being automatically deleted if you forget to manually renew them. The auto-renewal rules are as follows:

- The first auto-renewal date is based on when the GaussDB instance expires and the billing cycle.
- The auto-renewal period of a GaussDB instance depends on the subscription term. Monthly subscriptions renew each month, and yearly subscriptions renew each year.
- You can enable auto-renewal any time before a GaussDB instance expires. By default, the system will make the first attempt to charge your account for the renewal at 03:00 seven days before the expiry date. If this attempt fails, it will make another attempt at 03:00 every day until the subscription is renewed or expires.
- After auto-renewal is enabled, you can still renew the DB instance manually if you want to. After a manual renewal is complete, auto-renewal is still valid, and the renewal fee will be deducted from your account seven days before the new expiry date.
- By default, the renewal fee is deducted from your account seven days before the new expiry date. You can change this auto-renewal payment date as required.

For more information about auto-renewal rules, see [Auto-Renewal Rules](#).

Prerequisites

The yearly/monthly DB instance is not expired.

Auto-renewal has been enabled during the purchase.

You can enable auto-renewal on the GaussDB instance purchase page, as shown in [Figure 6-7](#). For details, see [Buying an Instance](#).

Figure 6-7 Enabling auto-renewal

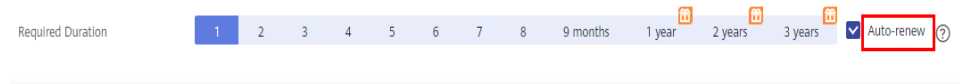

Enabling Auto-Renewal on the Renewals Page

Step 1 Log in to the management console.

Step 2 Hover over **Billing & Costs** in the upper part of the console and choose **Renewal** from the drop-down list.

The **Renewals** page is displayed.

Step 3 Set the search criteria.

- You can view the resources for which auto-renewal has been enabled on the **Auto Renewals** page.
- You can enable auto-renewal for resources on the **Manual Renewals**, **Pay-per-Use After Expiration**, and **Renewals Canceled** pages.

Figure 6-8 Renewals

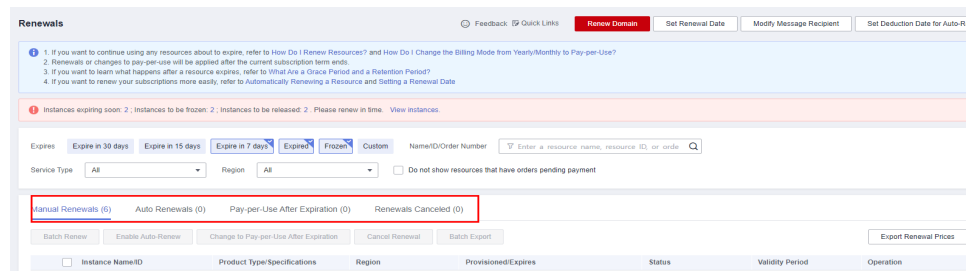

Step 4 Enable auto-renewal for yearly/monthly instances.

- Enabling auto-renewal for a single instance: Locate the instance that you want to enable auto-renewal for and choose **More > Enable Auto-Renew** in the **Operation** column.

Figure 6-9 Enabling auto-renewal for a single instance

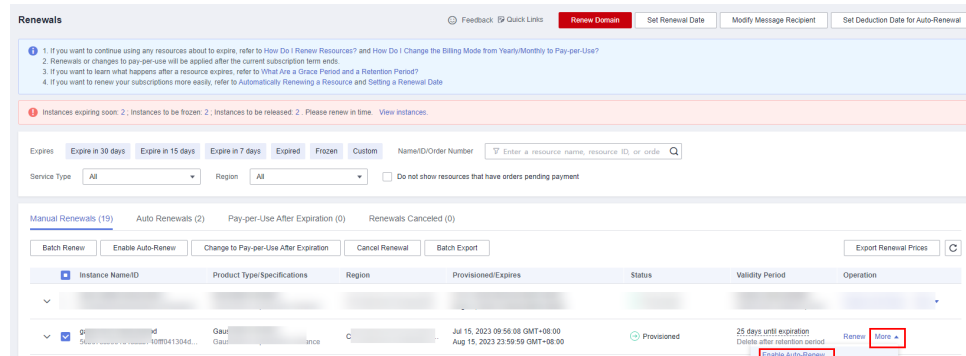

- Enabling auto-renewal for multiple instances at the same time: Select the instances that you want to enable auto-renewal for and click **Enable Auto-Renew** above the list.

Figure 6-10 Enabling auto-renewal for multiple instances

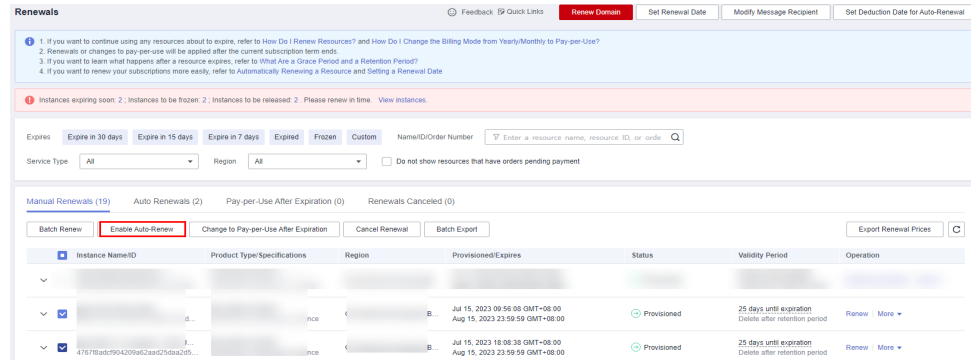

Step 5 Select a renewal period, specify the auto-renewal times, and click **Pay**.

Figure 6-11 Enabling auto-renewal

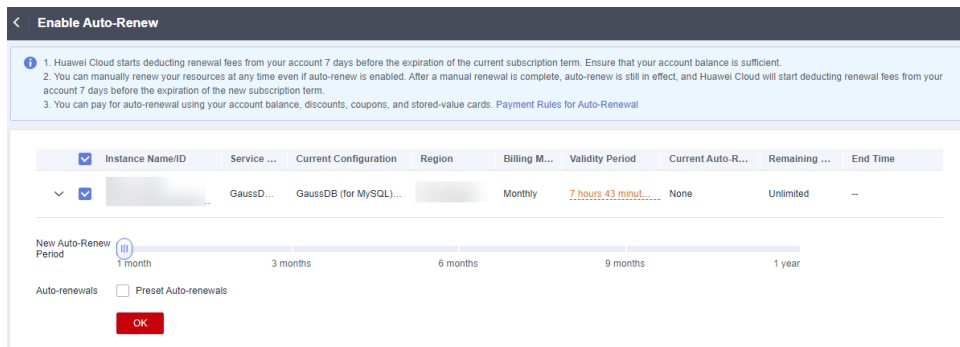

----End

7 Bills

You can view the resource usage and bills for a different billing cycles on the **Bills** page in the Billing Center.

Billing Generation

Transaction records for yearly/monthly subscriptions are generated immediately after being paid for.

A pay-per-use instance is billed by the hour, day, or month, depending on the instance's usage type. Pay-per-use GaussDB instances are billed by the hour.

You are not charged immediately after a record is generated. For example, if a pay-per-use DB instance (which is billed on an hourly basis) is deleted at 08:30, you will still have expenditures for the 08:00 to 09:00 hour, but you will not likely be billed for the 08:00 to 09:00 hour until about 10:00. On the **Bills** page of the Billing Center, select the **Bill Details** tab. **Expenditure Time** in the bill indicates the time when the pay-per-use resource is used.

Viewing Bills of a Specific Resource

[Method 1: Use the instance ID to search for a bill.]

Step 1 [Log in to the management console.](#)

Step 2 Click  in the upper left corner and select a region and a project.

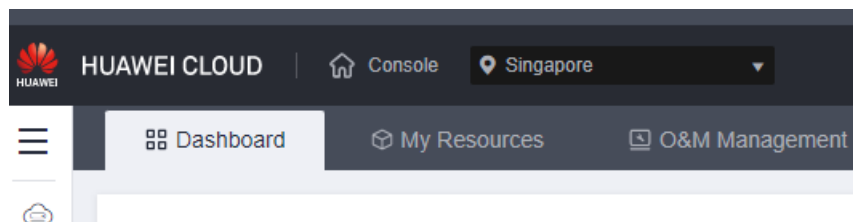

Step 3 Click  in the upper left corner of the page and choose **Databases** > **GaussDB**. The GaussDB console is displayed.

Step 4 On the **Instances** page, click the icon shown in the figure below to copy the ID of the target instance.

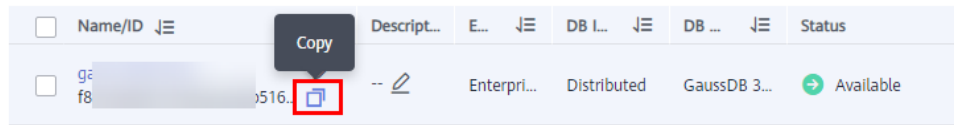
Figure 7-1 Copying the instance ID

Step 5 On the top menu bar, choose **Billing & Costs > Bills**.

The **Bills** page is displayed.

Step 6 On the **Bill Details** tab, select **Resource ID** as the filter, enter the instance ID obtained in **Step 4**, and click the  icon.

Figure 7-2 Searching for a bill

By default, bill details are displayed by usage and billing cycle. You can choose other display options as required.

----End

[Method 2: Use the instance name to search for a bill.]

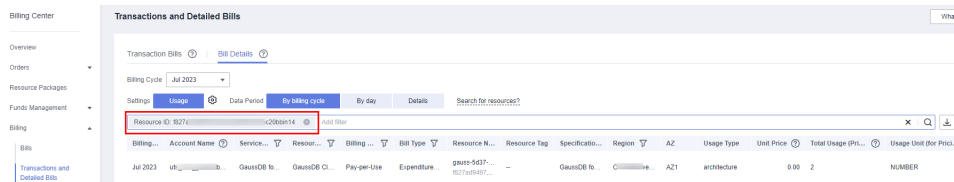
Step 1 **Log in to the management console.**

Step 2 Click  in the upper left corner and select a region and a project.

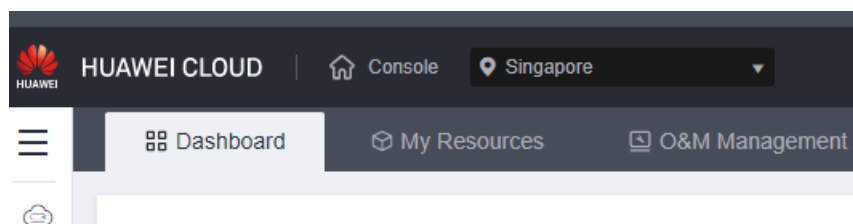

Step 3 Click  in the upper left corner of the page and choose **Databases > GaussDB**. The GaussDB console is displayed.

Step 4 On the **Instances** page, click the name of the target instance.

The **Basic Information** page is displayed.

Step 5 Click the icon shown in the figure below to copy the instance name.

Figure 7-3 Copying the instance name

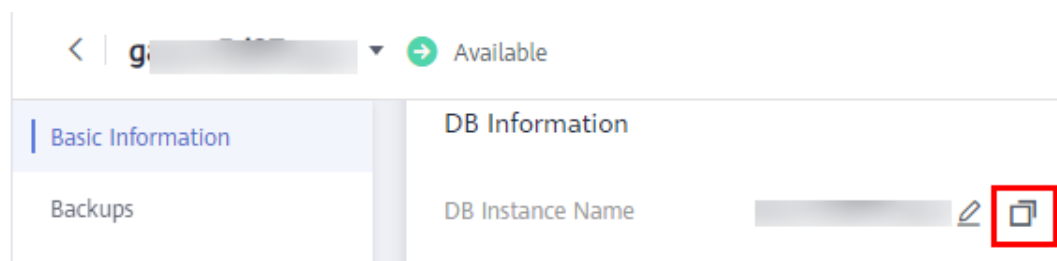

Step 6 On the top menu bar, choose **Billing & Costs > Bills**.

The **Bills** page is displayed.

Step 7 On the **Bill Details** tab, select **Resource Name** as the filter, enter the instance name obtained in **Step 5**, and click the  icon.

Figure 7-4 Searching for a bill



By default, bill details are displayed by usage and billing cycle. You can choose other display options as required.

----End

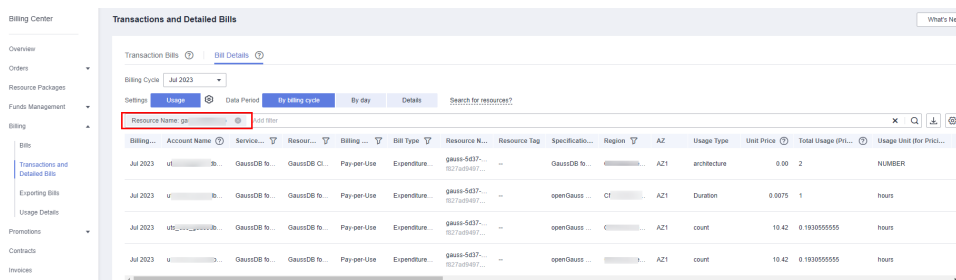
Scenario Example: Checking the Usage Consistency

Assume that you purchased a pay-per-use GaussDB instance at 10:09:06 on April 8, 2023 and deleted it later that day, at 12:09:06.

- Transaction records
Pay-per-use DB instance usage is calculated by the second but billed on an hourly basis. You can check the transaction records against the actual usage. The billed resources are billed separately. For details, see [Table 7-1](#) (taking storage as an example).

Table 7-1 DB instance transaction records

Service Type	GaussDB
Resource Type	Storage

Billing Mode	Pay-per-use
Expenditure Time	For the period of time from 10:09:06 to 12:09:06 on April 08, 2023, 6 transaction records would be generated for the resource usage in the following periods: <ul style="list-style-type: none"> • 2023/04/08 10:09:06 - 2023/04/08 11:00:00 • 2023/04/08 11:00:00 - 2023/04/08 12:00:00 • 2023/04/08 12:00:00 - 2023/04/08 12:09:06
List Price	List price on the official website = Usage x Unit price x Capacity In this example, 480 GB of storage was used by the GaussDB instance for 3,054 seconds in the first period, and the unit price is \$0.00084 USD/GB/hour. The list price for the first period = $(3054 \div 3600) \times 0.00084 \times 480 = \0.342048 USD. Similarly, you can calculate the GaussDB list price for the other periods. The unit price of GaussDB resources can be obtained on the GaussDB Pricing Details page.
Discounted Amount	Discounts offered for cloud services, for example, commercial discounts, partner authorized discounts, and promotional discounts. It is the discounted amount based on the list price.
Truncated Amount	The billing of Huawei Cloud is calculated to the 8th decimal place. However, the amount due is truncated to the 2nd decimal place. The third and later decimal places are referred to as the truncated amounts. Take the first period as an example. The truncated amount is \$0.002048 USD.
Amount Due	Amount due = List price - Discount amount - Truncated amount Take the first period as an example. If the discount amount is 0, the amount due is \$0.34 USD (0.342048 - 0 - 0.002048).

- DB instance bill details

Bill details can display in multiple ways. By default, the bill details of a resource are displayed by usage and by billing cycle. [Table 7-2](#) illustrates the DB instance bill details, which can be used to check against the actual usage (taking storage as an example).

Table 7-2 DB instance bill details

Service Type	GaussDB
Resource Type	Storage
Billing Mode	Pay-per-use

Resource Name/ID	DB instance name and ID Example: gauss-e4c4, 41986722eb1041f886d28a90fd610067in14
Specifications	Storage space type and capacity Example: Ultra-high I/O, 480 GB
Usage Type	Duration for a pay-per-use DB instance
Unit Price	When pay-per-use billing is used, the unit price is only provided if the amount is equal to the usage multiplied by the unit price. No unit price is provided in other pricing modes, for example, tiered pricing. You can search for the unit price for pay-per-use GaussDB instances on GaussDB Pricing Details .
Unit	USD/GB/hour, which is displayed on GaussDB Pricing Details
Usage	Depends on the unit of the unit price, which is USD/GB/hour. Storage usage is billed by the hour. Example: 2 hours
Usage Unit	Hour
List Price	List price on the official website = Usage x Unit price x Capacity In this example, 480 GB of storage was used for 2 hours, and the unit price is \$0.00084 USD/GB/hour. List price = 2 x 0.00084 x 480 = \$0.8064 USD. The unit price of GaussDB resources can be obtained on the GaussDB Pricing Details page.
Discounted Amount	Discounts offered for cloud services, for example, commercial discounts, partner authorized discounts, and promotional discounts. It is the discounted amount based on the list price.
Amount Due	Amount that should be paid for used cloud services after discounts are applied.

8 Arrears

If your configured payment method is unable to pay for your bill, your account will be in arrears. You will need to update your payment method or to top up your account in a timely manner if you want to continue using your cloud services.

Arrears Reason

If your DB instance is not billed at a yearly/monthly basis, your account falls into arrears any time your configured payment method is unable to pay for the used resources on the pay-per-use basis.

Arrears Impact

- Yearly/Monthly
This is a pre-paid billing mode, so you can continue using yearly/monthly DB instances even if your account is in arrears. However, you cannot perform operations such as buying new DB instances, upgrading the instance specifications, or renewing DB instances, because they will generate new expenditures.
- Pay-per-use
If your configured payment method is unable to pay a bill for pay-per-use DB instances, the instances enter a grace period. You are still responsible for expenditures generated during the grace period. You can view the expenditures on the **Overview** page of the Billing Center and pay any past due balance as needed.

If you do not bring your account balance current before the grace period expires, the DB instance turns to **Frozen** and enters a retention period.

After the retention period ends, the compute resources (vCPUs and memory) and EIPs will be released and cannot be restored.

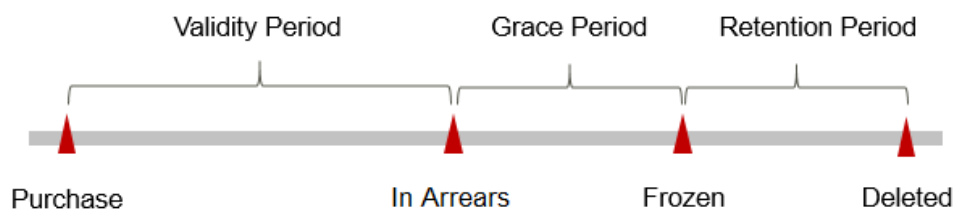
Figure 8-1 Lifecycle of a pay-per-use DB instance**NOTE**

The grace period and retention period are both 15 days.

Avoiding and Handling Arrears

Make sure you have a valid payment method configured as soon as possible after your account is in arrears. For details, see [Topping Up an Account](#).

If a DB instance is no longer used, you can delete it to avoid generating further expenditures.

To help make sure your account never falls into arrears, you can configure the **Balance Alert** on the **Overview** page of the Billing Center. Then, any time an expenditure quota drops to below the threshold you specify, Huawei Cloud automatically notifies you by SMS or email.

9 Billing Termination

Yearly/Monthly Resources

When you purchase a yearly/monthly resource, for example, a yearly/monthly GaussDB instance, you make a one-time up-front payment. By default, the billing automatically stops when the purchased subscription expires.

- If you no longer need a resource, but the subscription has not yet expired, you can unsubscribe from it. Depending on what coupons were used for the purchase and on if 5-day unconditional unsubscription rules apply, Huawei Cloud may issue you a refund. For details about unsubscription rules, see [Unsubscriptions](#).
- If you have enabled auto-renewal but no longer wish to automatically renew the subscription, disable it before the auto-renewal date (7 days before the expiration date by default) to avoid unexpected expenditures.

Pay-per-Use Resources

If pay-per-use resources, for example, pay-per-use GaussDB instances, are no longer required, delete them in a timely manner.

Searching for Resources from Bills and Stopping Billing

To ensure that all related resources are deleted, you can search the billing records by resource ID, and then delete the resources you identify in this way.

[Method 1: Use the resource ID in the bill to search for a resource.]

Step 1 [Log in to the management console](#).

Step 2 Click  in the upper left corner and select a region and a project.

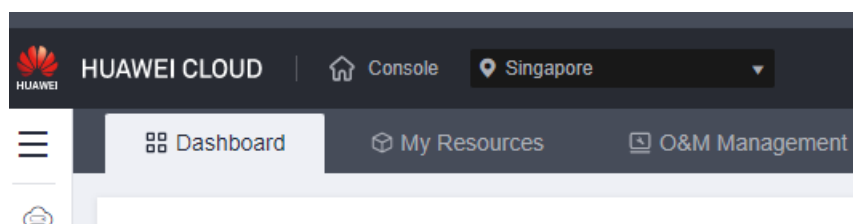



Step 3 On the top menu bar, choose **Billing & Costs > Bills**.

The **Bills** page is displayed.

Step 4 Choose **Transactions and Detailed Bills** and click **Bill Details**. From there, click the icon shown in the following figure to copy the resource ID.

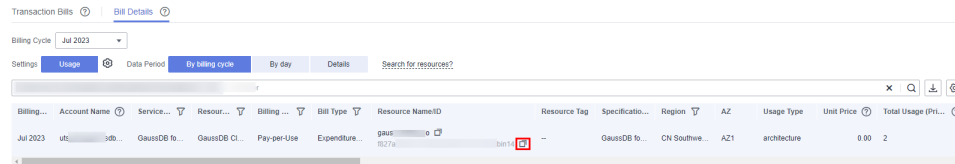
Figure 9-1 Copying the resource ID



Step 5 Click  in the upper left corner of the page and choose **Databases > GaussDB**. The GaussDB console is displayed.

Step 6 Select **DB instance ID** as the filter, enter the resource ID copied in **Step 4**, and click the  icon to search for the resource.

Figure 9-2 Searching for the resource



Step 7 Click **More > Delete** in the **Operation** column to delete the target DB instance. Ensure that the resource is not found in the list.

NOTE

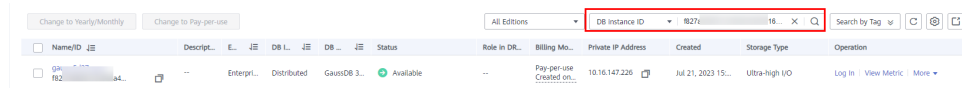
You are billed one hour after the resource usage is calculated, so a bill may still be generated after the pay-per-use resource is deleted. For example, if you delete a DB instance (which is billed on an hourly basis) at 08:30, the expenditures for that hour from 08:00 to 09:00 are usually not billed until about 10:00.

----End

[Method 2: Use the resource name in the bill to search for a resource.]

Step 1 [Log in to the management console](#).

Step 2 Click  in the upper left corner and select a region and a project.

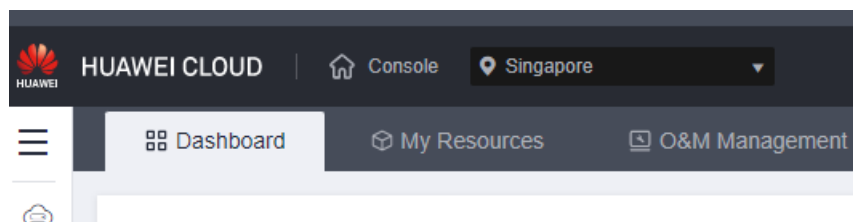



Step 3 On the top menu bar, choose **Billing & Costs > Bills**.

The **Bills** page is displayed.

- Step 4** Choose **Transactions and Detailed Bills** and click **Bill Details**. From there, click the icon shown in the following figure to copy the resource name.

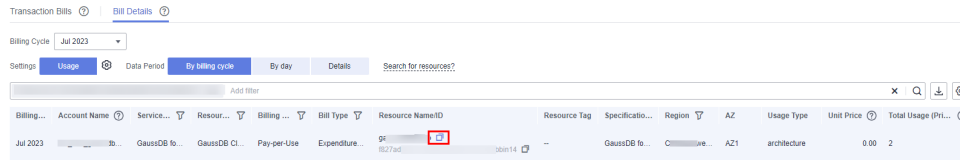
Figure 9-3 Copying the resource name



- Step 5** Click  in the upper left corner of the page and choose **Databases > GaussDB**. The GaussDB console is displayed.

- Step 6** Enter the name of the DB instance copied in **Step 4** in the search box and click .

Figure 9-4 Searching for the resource



- Step 7** Click **More > Delete** in the **Operation** column to delete the target DB instance. Ensure that the resource is not found in the list.

NOTE

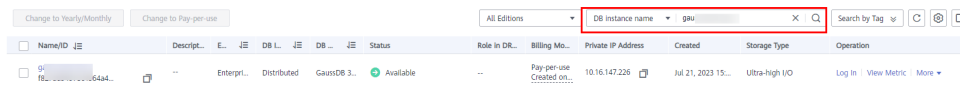
You are billed one hour after the resource usage is calculated, so a bill may still be generated after the pay-per-use resource is deleted. For example, if you delete a DB instance (which is billed on an hourly basis) at 08:30, the expenditures for that hour from 08:00 to 09:00 are usually not billed until about 10:00.

----End

10 Cost Management

As you migrate more of your workloads to the cloud, managing cloud costs becomes more important. For example, you may be more concerned with cost management when using GaussDB instances. The following describes how to manage costs in terms of cost composition, allocation, analysis, and optimization. Optimizing costs can help you maximize return on investment.

Cost Composition

GaussDB instance costs consist of two parts:

- Resource costs: cost of resources and resource packages, depending on the billed items of GaussDB. For details, see [Billed Items](#).
- O&M costs: labor costs incurred during the use of DB instances.

Figure 10-1 GaussDB instance costs

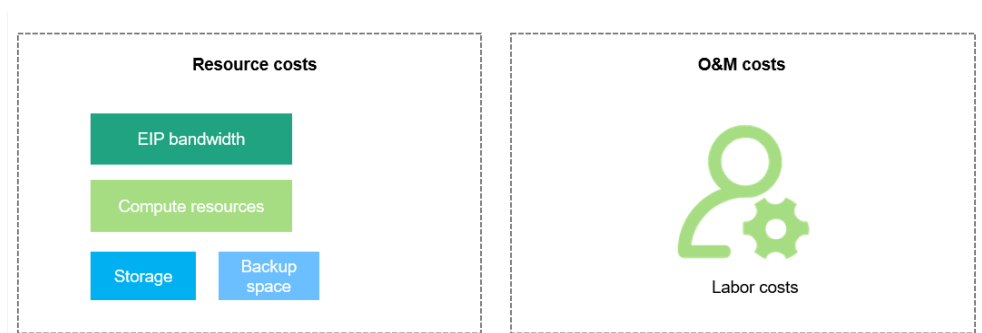

Cost Allocation

A good cost accountability system is a prerequisite for cost management. It ensures that departments, business teams, and owners are accountable for their respective cloud costs. An enterprise can allocate cloud costs to different teams or projects so as to have a clear picture of their respective costs.

Huawei Cloud [Cost Center](#) provides various tools for you to group costs in different ways. You can experiment with these tools and find a way that works best for you.

- **By linked account**

The enterprise master account can manage costs by grouping the costs of its member accounts by linked account. For details, see [Viewing Costs by Linked Account](#).
- **By enterprise project**

Before allocating costs, enable Enterprise Project Management Service (EPS) and plan your enterprise projects based on your organizational structure or service needs. When purchasing cloud resources, select an enterprise project so that the costs of the resources will be allocated to the selected enterprise project. For details, see [Viewing Costs by Enterprise Project](#).

Figure 10-2 Selecting an enterprise project for a DB instance



- **By cost tag**

You can use tags to sort your Huawei Cloud resources in a variety of different ways, for example, by purpose, owner, or environment. The following is the process of managing costs by predefined tags (recommended).

Figure 10-3 Adding tags for a DB instance

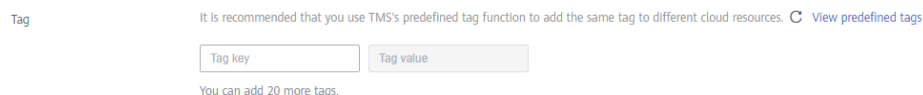
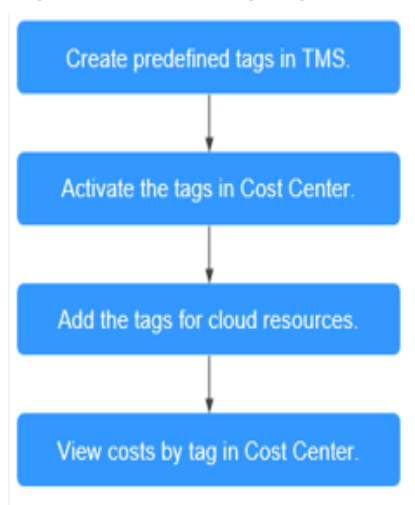

For details, see [Viewing Costs by Cost Tag](#).

- **By cost category**

You can use cost categories provided by [Cost Center](#) to split shared costs. Shared costs are the costs of resources (compute, network, storage, or resource packages) shared across multiple departments or the costs that cannot be directly split by cost tag or enterprise project. These costs are not directly attributable to a singular owner, and they cannot be categorized into a singular cost type. In this case, you can define cost splitting rules to fairly

allocate these costs among teams or business units. For details, see [Viewing Cost By Cost Category](#).

Cost Analysis

To precisely control and optimize your costs, you need a clear understanding of what parts of your enterprise incurred different costs. **Cost Center** visualizes your original costs and amortized costs using various dimensions and display filters for cost analysis so that you can analyze the trends and drivers of your service usage and costs from a variety of perspectives or within different defined scopes.

You can also use cost anomaly detection provided by **Cost Center** to detect unexpected expenses in a timely manner. In this way, costs can be monitored, analyzed, and traced.

For details, see [Performing Cost Analysis to Explore Costs and Usage](#) and [Enabling Cost Anomaly Detection to Identify Anomalies](#).

Cost Optimization

- **Cost control**

You can create different types of budgets on the **Budgets** page of Cost Center to track your costs against the budgeted amount you specified. If the budget thresholds you defined are reached, Cost Center will send alerts to the recipients you configured. You can also create budget reports and specify recipients to receive budget alerts if any at a frequency you configured.

Suppose you want to create a monthly budget of \$2,000 USD for pay-per-use DB instances and expect to receive an alert if the forecasted amount exceeds 80% of the budgeted amount. You can refer to the following budget information.

Figure 10-4 Basic budget information

The screenshot shows the 'Budget Details' form with the following fields and options:

- Budget Name:** GaussDB
- Reset Period:** Daily, Monthly (selected), Quarterly, Yearly. A note states: 'Budget evaluation begins at 00:00 GMT+08:00 on the 1st day of the start month and will be reset to zero at 00:00 GMT+08:00 on the 1st day of each month moving forward.'
- Budget Duration:** Recurring (selected), Expiring
- Start Time:** 2023/10
- Allocation:** Fixed (selected), Monthly, Dynamic
- Budgeted Amount (USD):** 2000. A note indicates: 'Last month's cost: \$994.94 USD'

Figure 10-5 Defining the budget scope

Service Type	All	▼
Linked Account	All	▼
Region	All	▼
Specifications	All	▼
Usage Type	All	▼
Cost Tag	All	▼
Cost Categories	All	▼
Enterprise Project	All	▼
Business Entity	All	▼
Bill Type	All	▼
Billing Mode	Include	▲
Pay-per-Use		1
AZ	All	▼

Figure 10-6 Setting a budget alert

Thresholds Alerts are sent when the actual cost is higher than 80% (\$1,600.00) of the forecasted cost.

[Add threshold](#)

Recipients (Email)s [Select From Contacts](#)

For details, see [Enabling Forecasting and Creating Budgets to Track Cost and Usage](#).

- **Resource rightsizing**

Cost Center analyzes your historical CPU and other resource usage to identify idle DB instance resources and generate resource rightsizing recommendations. These rightsizing opportunities are places where you can reduce costs. You can also identify resources with high costs based on the analyses on the **Cost Analysis** page and use Cloud Eye to monitor resource usage. By doing this, you can determine the causes of high costs and take optimization measures accordingly. You can:

- Monitor resource usage and evaluate whether the current configuration is more than you need, for example, you can monitor the usage of CPUs, memory, EVS disks, and bandwidth.
- Identify idle resources, for example, there may be unattached EVS disks or unbound EIPs.

- **Billing mode selection**

Different types of services have different requirements on resource usage periods, so the most economical billing mode for one resource may not be the best option for another resource.

- For mature services that tend to be stable for the long term, select the yearly/monthly billing.
- For short-term, unpredictable services that experience traffic bursts and cannot afford to be interrupted, select the pay-per-use billing.